

**ADDENDUM NO. 3
JANUARY 15, 2025
FOR
ROOSEVELT PARK POOL EQUIPMENT UPGRADES
MINOT PARK DISTRICT
MINOT, ND
DECEMBER 2024**



This Addendum No. 3 forms a part of the Project Manual and modifies the original Bidding Documents as noted within this Addendum. All provisions of the Project Manual not in conflict with this Addendum shall remain in full force. Acknowledge receipt of this Addendum on the outside of the bid envelope and in the space provided on the Bid Form. Failure to do so may subject the Bidder to disqualification.

This addendum consists of four (4) pages and one (1) attachment.

SPECIFICATIONS

SECTION 00 11 13 C111 ADVERTISEMENT FOR BIDS

- 1) **CHANGE** the bid date and time to **Tuesday, January 21, 2025 at 11:00 am CST.**

SECTION 00 43 02 – C430 BID BOND FORM

- 1) **CHANGE** bid due date to **January 21, 2025.**

SECTION 00 73 80 – SUPPLEMENTAL CONDITIONS

- 1) **ADD** SC 14.02.D:

D. The Owner will submit the plans and specifications to the First District Health Unit and pay for all review fees.

- 2) **ADD** SC 14.02.E:

E. The Owner will provide for the pool to be at its normal operating water level for all system testing and integration.

Section 13 61 13 – POOL CONTROL SYSTEM GENERAL REQUIREMENTS

- 1) **DELETE** Section 13 61 13 – Pool Control System General Requirements

Section 13 61 21 – POOL CONTROL SYSTEM TESTING

- 1) **DELETE** Section 13 61 21 Pool Control System Testing

DRAWINGS

Sheet P201

- 1.2/P201 - HOLDING TANK – ENLARGED PLAN - **Revise** main return size to 12" and gutter return to 8", to match the civil plans.

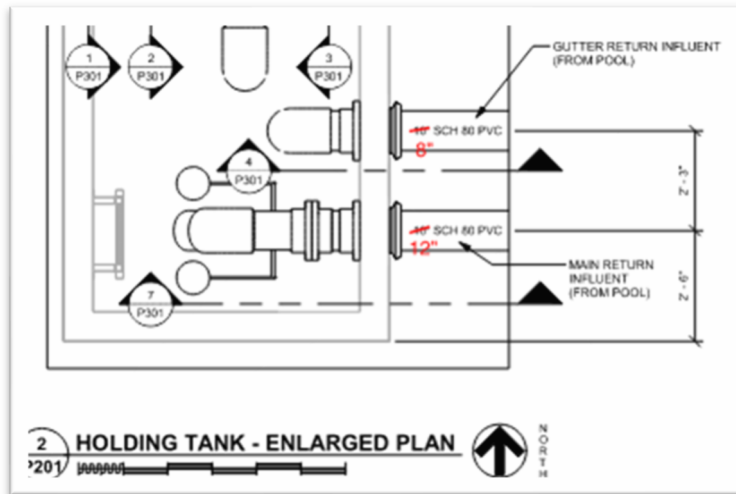

Sheet P301

- 1) 5/P301 - SECTION @ DRY PIT - **Revise** precoat line from 4" to 6" per sketch below.

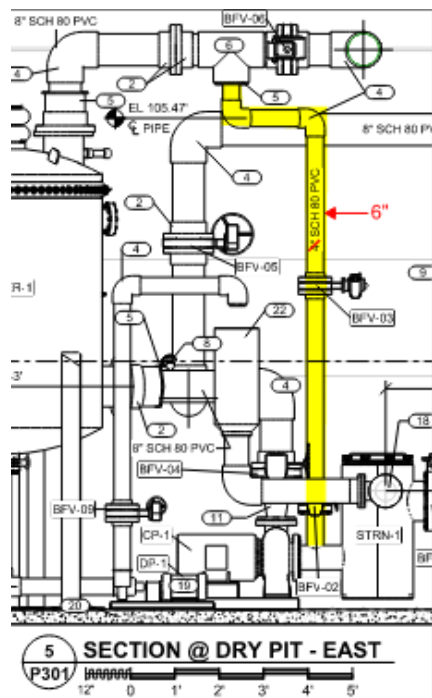

- 2) 4/P301 - 10-INCH INFLUENT NORTH - HT - **Revise** pipe size to 8".

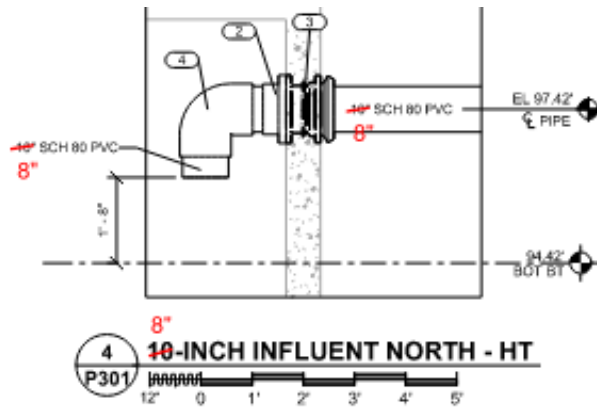

g

- 3) 7/P301 - 10-INCH INFLUENT SOUTH - HT - **Revise** pipe size to 12".

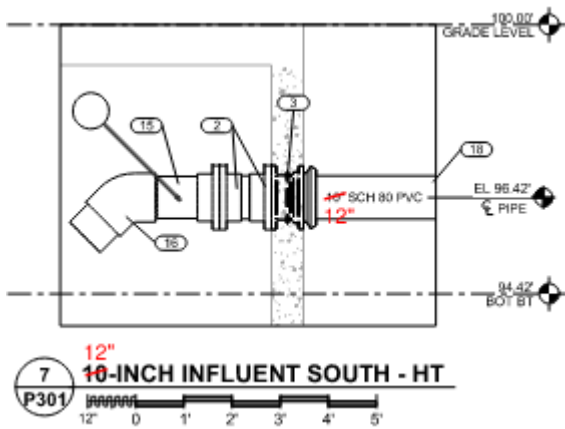

Sheet P502

- 1) **ADD** Sheet P502 – POOL CONTROL SCHEMATIC.

Sheet P601

- 1) PUMP SCHEDULE – **ADD** Drain Pump (DP-1). Pump to be Vertiflo model # 2122-3x3 w/ 7.5HP motor. Electrical Characteristics – 208V-3ph.
- 2) VALVE SCHEDULE –
- a. **Revise** BFV-02 – PRE-COAT – MANUAL to be 6".
 - b. **Revise** BFV-03 – PRE-COAT – PNEUMATIC to be 6".

VALVE SCHEDULE				
TAG	DESCRIPTION	VALVE SIZE	CONNECTION	TYPE
SCV-01	STRAINER INFLUENT CHECK	10"	FLANGED	CHECK
BFV-01	STRAINER INFLUENT	10"	WAFER	BUTTERFLY
BFV-02	PRE-COAT - MANUAL	6" ←	WAFER	BUTTERFLY
BFV-03	PRE-COAT - PNEUMATIC	6" ←	WAFER	BUTTERFLY

Sheet E601

1) Contractor shall provide new 3P breaker within Panel LP-1, and NEMA 1 combination motor starter sized appropriately to feed Drain Pump **DP-1**. Contractor may coordinate reuse of existing breakers with Electrical Engineer if deemed applicable. Locate breaker near other large feeders and include within new directory per Div 26 panel specifications. Label breaker according to Process schedule naming and tagging.

PRIOR APPROVALS

1) Century-Line Pipe-Penetration Sleeves - Trumbull

ATTACHMENT LIST TO THIS ADDENDUM

1) Sheet P502 (revision 1)

End of Addendum No. 3

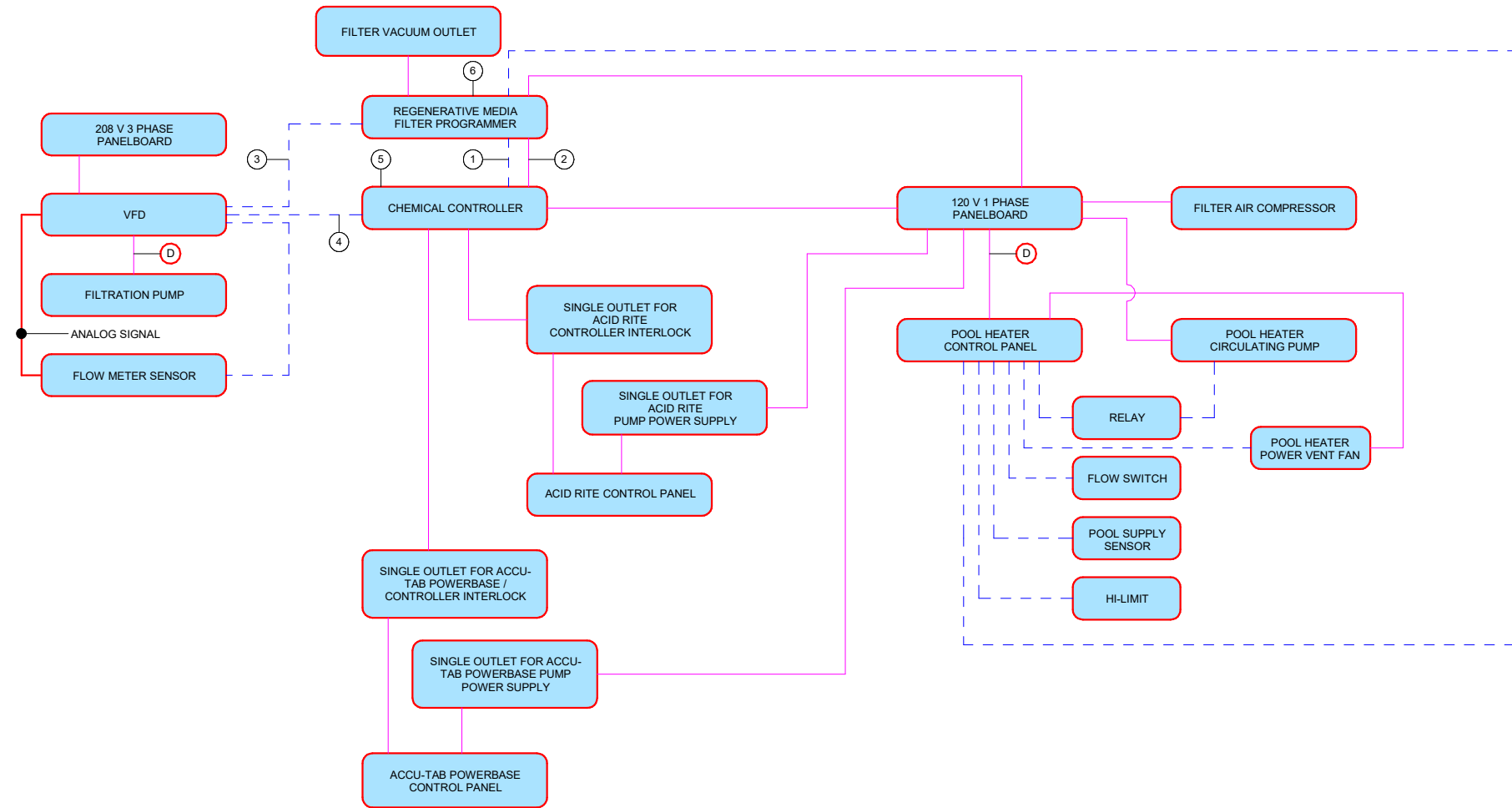

SEQUENCE OF OPERATIONS - SWIMMING POOL WITH REGENERATIVE MEDIA FILTER SYSTEM

FILTRATION PUMP:

- THE NORMAL OPERATING POSITION OF THE FILTRATION PUMP VFD HOA SWITCH IS THE "AUTO" POSITION. IN THE "AUTO" POSITION THE FILTRATION PUMP SHALL RUN AT DESIGN FLOW (FREQUENCY).
- THE FILTRATION PUMP SHALL RUN WHEN THE FILTER PROGRAMMER IS IN THE FILTRATION MODE.
- THE FILTRATION PUMP SHALL RUN AT REDUCED SPEED WHEN THE FILTER PROGRAMMER IS IN THE PRECOAT MODE. COORDINATE SPEED SETTING WITH FILTER COMMISSIONING AGENT.
- THE FILTRATION PUMP SHALL NOT RUN WHEN THE FILTER PROGRAMMER IS IN THE BUMP OR OFF MODES.

FILTER PROGRAMMER:

- THE FILTER PROGRAMMER'S NORMAL OPERATION IS IN FILTRATION MODE.
- THE FILTER BUMP CYCLE IS ACTIVATED BY THE FILTER PROGRAMMER EITHER AUTOMATICALLY OR BY A PUSH BUTTON.
- THE FILTER PROGRAMMER SHALL RECEIVE A FEEDBACK SIGNAL FROM THE FILTRATION PUMP VFD THAT THE FILTRATION PUMP IS OPERATING.
- THE FILTER PROGRAMMER IS SUPPLIED WITH AUXILIARY CONTACTS TO DISABLE OTHER POOL EQUIPMENT WHEN THE FILTRATION PUMP IS NOT RUNNING DUE TO PUMP FAILURE (FEEDBACK SIGNAL FROM VFD) OR THE PROGRAMMER IS IN THE BUMP OR OFF MODES.

CHEMICAL CONTROLLER & CHEMICAL FEED OUTLETS:

- THE CHEMICAL CONTROLLER CPU SHALL BE POWERED AT ALL TIMES.
- THE CHEMICAL CONTROLLER AND CHEMICAL FEED OUTLETS SHALL BE INTERLOCKED SUCH THAT IF THE FILTRATION PUMP FAILS (SIGNAL VIA THE FILTER PROGRAMMER), THE IN-LINE FLOW SWITCH IS NOT MADE OR THE FILTRATION PROGRAMMER IS IN THE BUMP OR OFF MODE; THE FEED OUTLETS ARE INACTIVE.
- CHEMICAL CONTROLLER FEED OUTLETS ENERGIZES / DE-ENERGIZES SANITIZER AND pH FEED BASED UPON POOL WATER CHEMISTRY.

CHEMICAL FEED PUMPS:

- THE CHEMICAL FEED PUMPS ARE POWERED BY THE CHEMICAL FEED OUTLETS.

ACCU-TAB POWERBASE CHLORINE FEEDER:

- THE ACCU-TAB POWERBASE CONTROLLER IS POWERED ON / OFF BY THE CHEMICAL CONTROLLER FEED OUTLET.
- THE ACCU-TAB POWERBASE CHLORINE BOOSTER PUMP IS POWERED BY THE PANELBOARD.
- THE ACCU-TAB POWERBASE CHLORINE BOOSTER PUMP IS ALWAYS ON.
- THE ACCU-TAB POWERBASE CONTROLLER ACTIVATES THE ACCU-TAB POWERBASE CHLORINE BOOSTER PUMP.

POOL HEATER:

- THE POOL HEATER SHALL BE INTERLOCKED SUCH THAT IF THE FILTRATION PUMP FAILS (SIGNAL VIA THE FILTER PROGRAMMER), OR THE FILTRATION PROGRAMMER IS IN THE BUMP OR OFF MODE; THE HEATER IS INACTIVE.
- THE POOL HEATER CIRCULATING PUMP IS CONTROLLED BY THE POOL HEATER CONTROLLER.
- POOL HEATER CYCLES ON AND OFF AS NEEDED BASED UPON POOL WATER TEMPERATURE.
- POOL HEATER IS INTERLOCKED WITH MANUFACTURER SUPPLIED FLOW SWITCH AND HI-LIMIT TEMP SENSORS.

FLOW METER:

- WHEN FLOW METER POWER SUPPLY IS ENERGIZED, THE FLOW METER SENSOR SHALL PROVIDE THE FLOW READOUT IN GPM.
- THE FLOW METER SHALL PROVIDE FLOW DATA TO THE INDICATED VFD AND CONTROL SPEED OF THE VFD BASED ON THE FLOW.

POOL EQUIPMENT OPERATING MODES

FILTRATION PROGRAMMER OPERATING MODE	FILTRATION PUMP	CHEMICAL CONTROLLER	CHLORINE FEED	ACID FEED	HEATER
BUMP	O	X	O	O	O
PRECOAT	REDUCED SPEED	X	O	O	O
OFF	O	X	O	O	O
FILTRATION	X	X	X	X	X

"X" INDICATES THE EQUIPMENT IS ENERGIZED / RUNNING.
"O" INDICATES THE EQUIPMENT IS NOT ENERGIZED.

NOTES:

- LOW VOLTAGE <=24V. ALL LOW VOLTAGE WIRING IS SUPPLIED, INSTALLED AND CONNECTED BY THE CONTRACTOR.
- IF CONDUIT IS REQUIRED BY CODE FOR LOW VOLTAGE WIRING, THEN THIS MUST BE SPECIFIED BY THE ELECTRICAL CONSULTANT AND INSTALLED BY THE ELECTRICAL CONTRACTOR.
- IF CODE REQUIRES THAT LOW VOLTAGE WIRING IS INSTALLED BY A LICENSED ELECTRICAL CONTRACTOR THEN THIS MUST BE SPECIFIED BY THE ELECTRICAL CONSULTANT.
- CONDUIT, WIRE SIZES, AND SHIELDING REQUIREMENTS SHALL BE DETERMINED & SPECIFIED BY THE ELECTRICAL CONSULTANT AS NEEDED PER LOCAL BUILDING AND ELECTRICAL CODE REQUIREMENTS.
- THIS SCHEMATIC DRAWING IS NOT AN ELECTRICAL INSTALLATION DIAGRAM AND IS FOR REFERENCE ONLY. IT IS THE RESPONSIBILITY OF THE CONTRACTOR TO COORDINATE ALL INTERLOCKS WITH THE ELECTRICAL CONTRACTOR. THE CONTRACTOR IS RESPONSIBLE TO PROVIDE AN OPERATING SYSTEM PER THE SEQUENCE OF OPERATIONS.

KEYNOTES: (#)

- TDS CONTROL.
- PROVIDE (2) WIRES FOR CHEMICAL CONTROLLER INTERLOCK CONNECTION FROM FILTER PROGRAMMER CONTACTS #45 AND #46 TO THE CHEMICAL CONTROLLER RUN / STOP CONTACTS. WHEN FILTER PROGRAMMER IS IN OFF, PRECOAT, OR BUMP MODE. OR THE FILTRATION PUMP IS NOT RUNNING DUE TO POWER FAILURE (SIGNAL FROM VFD), THIS CONNECTION SHALL DISABLE THE CHEMICAL CONTROLLER AND DEACTIVATE THE CHEMICAL FEED TO THE SYSTEM.
- WHEN FILTER PROGRAMMER IS OFF, PRECOAT OR BUMP MODE OR THE FILTRATION PUMP NOT RUNNING DUE TO POWER FAILURE, THIS CONNECTION SHALL DEACTIVATE THE CONNECTED POOL EQUIPMENT. COORDINATE WIRING REQUIREMENTS WITH EQUIPMENT MANUFACTURER.
- VFD ANALOG OUTPUT REPEAT FLOW METER DATA TO CHEMICAL CONTROLLER.
- A FLOW CELL WITH SHUT-OFF SWITCH SHALL COME PREASSEMBLED AND WIRED TO THE CHEMICAL CONTROLLER. CONTRACTOR SHALL ASSURE CHEMICAL CONTROLLER FLOW CELL ASSEMBLY IS WORKING PROPERLY AND DEACTIVATES CHEMICAL FEED UNDER A NO FLOW CONDITION.
- ELECTRICIAN MUST MOUNT THE SMALL BOX ON THE FRAME OF THE DEFENDER FILTER IN THE PREDRILLED HOLES, CUT THE PLUG OFF THE VACUUM CORD AND HARD WIRE IT TO THE WIRES ALREADY IN THE SMALL BOX.

LEGEND:

- LOW VOLTAGE CONTROL OR POWER
- SUPPLY POWER
- CONTRACTOR TO COORDINATE WITH EQUIPMENT REQUIREMENTS
- ⓓ DISCONNECT - LOCATE AT EQUIPMENT PER CODE REQUIREMENTS



Certification of Individual Project Design Disciplines Are Included On Their Individual Drawings, Respectively



STATUS: CONSTRUCTION

SYM	DATE	DESCRIPTION
1	01/15/25	ADDITION #3

ROOSEVELT PARK POOL EQUIPMENT UPGRADES
Advanced Engineering and Environmental Services, LLC www.ae2s.com

THIS SHEET WAS ISSUED BY ADDENDUM #3

SHEET TITLE: CONTROL SYSTEM DIAGRAM		
CLIENT: MINOT PARK DISTRICT MINOT, NORTH DAKOTA	PREPARED BY: RMD	CHECKED BY: CJB
APPROVED BY: CJB	PROJECT NO: 11550-2024-003	SHEET DESIGNATOR: P
DATE DEC 20, 2024	SHEET NO: P502	ALT PROJECT NO: 00000-0000