



Date: December 23, 2024

Project: North Dakota Department of Commerce
Apple Creek Rest Area Renovation
Bismarck, ND

J2 Studio #: J22401

RE: Addendum #2

From: J2 Studio Architecture + Design
919 South 7th Street, Suite 400
Bismarck, ND 58504
Phone: (701) 255-1622
Fax: (701) 223-8927

To: All Invited Bidders

No. of Pages: 9 (4 - 8½ x 11 Addendum body, 2 – 8 1/2x11 Bid Form, 1 – 11x17 Drawing, 1 – 8 ½ x 11 Planholders List, 1 – 8 ½ x 11 Prebid Sign-in Sheet)

General

1. **Multiple Prime Bids are due on or before Wednesday, January 8th at 2:00pm.**
 - a. Bids shall be delivered to 1600 E. Century Avenue, Suite 6 before 2:00pm.
 - b. A public bid opening will be held at 2:00pm.
2. Bids shall be submitted in a double envelope with the Contractor's license and bid security submitted in a separate small envelope attached to a larger envelope containing the bid forms.
 - a. Bids shall be submitted per the specifications and state statute.
3. If plans and specifications were obtained through an exchange, and you wish to be included in the planholders list, contact J2 Studio.
4. A prebid walkthrough was held on site on December 18, 2024. The following were in attendance:
 - a. James Devine & Carrie Meyer – J2 Studio
 - b. Terrance Heiser – ND DOT Bismarck
 - c. Mike Jenson – ND Department of Commerce
 - d. John Klein – Apex Engineering Group
 - e. Allen Darling & Jayden Haider – Capital City Construction
 - f. Brandon Feser – Dakota West Contracting

919 S. 7th Street, Suite 400
Bismarck, ND 58504
Ph: (701) 255-1622 Fax: (701) 223-8927

- g. Matt Kimball – Northwest Contracting
 - h. Dave Reis – Roers Construction
 - i. Randy Koch – RK Electric
 - j. Brian Osmond – Oztech Electric
 - k. Jace Murschel – Magnum Electric
 - l. Jason Rodd – Edling Electric
 - m. Thomas Wolf – Skeels Electric
5. In addition to an overview of the project, the following items were discussed. Applicable items should be included in the Contract Document per this addendum. This is not a complete list of the work required. Contractors shall refer to the Contract Documents for the complete scope of work. All comments shall be reviewed by bidders.
- a. Project consists of a minor interior renovation within the westbound Apple Creek rest area for tourism upgrades for the ND Department of Commerce. The work consists of electrical upgrades for new Owner provided digital graphics (outside of this contract), installation of new static graphic and pamphlet displays, and removal and infill of existing coiling door.
 - b. There are no alternates for the project.
 - c. Asbestos testing shall be by the Owner.
 - d. Existing drawings shall be uploaded to the Dropbox site as part of this addendum.
 - e. There is no work in the east bound rest area.
6. The DOT requires a Right to Access permit for the work. Note that this will be carried by the Department of Commerce and is not required by the contractor.
7. Contractor shall the shop drawing process as soon as a Notice of Award/Notice to Proceed is given. Demolition and construction shall not start within the building until materials are delivered.

Specifications

Section 00 4100 Bid Form

1. Replace bid form in its entirety. No alternates on this project.

Section 10 1423 Panel Signage

1. Subparagraph 2.02.A.1; revise as follows:
 - a. 1. Basis-of-Design: MDC Digitally Printed Acrylic Divider Panels; refer to quote #40533792.

Electrical Specifications

1. Refer to attached electrical addendum.

Drawings

A001 Main Floor Demolition Plan

1. Specific Demolition Notes; remove #8 in its entirety.
 - a. Note that existing window sill and countertop will remain in place.
2. Drawing A/001; delete demolition note #8.

A101 Main Floor Renovation Plans & Details

1. Wall Type Schedule; revise as follows:
 - a. Revise wall type A as per attachment A1.
 - i. Note that infills locations will now be construction with stud.

- b. Delete reference to Wall Type Note #1; no longer needed.
2. Drawing 1/A101; revise as follows and per attachment A1.
 - a. Infill locations shall now be construction with 2 1/2" metal stud framing.
 - i. Location of wall coiling door infill shall be flush with the Storage 103 side of the wall.
 - ii. Location of wall at infill north of the family restroom shall be flush with the Lobby 102 side of the wall.
 - iii. Install control joints around all sides of the infill construction. Paint both sides of walls 'P1' to match existing CMU.
3. Add details 6 & 7/A101 as per attachment A1; refer to details for infill construction.

Electrical Drawings

1. Refer to attached electrical addendum.

Approved Equals

None

End of Addendum #1

December 19, 2024

J22401

Please add the following Addendum to the specifications that you have on file. The contractor shall acknowledge on the Bid Form receipt of this Addendum.

SPECIFICATIONS

1. Section 27 1000: Paragraph 2.07: Clarification; consolidation of cables into a larger conduit above the metal ceiling is acceptable. Contractor to insure continuous raceway from outlet location to the new network rack.

DRAWINGS

1. Clarification: For access above the existing metal panel ceiling the contractors shall review detail 3/A3.3WB of the original 1998 architectural drawings. There are 6 inches above the metal ceiling and the bottom of the joist and 24 inches between the metal ceiling and the roof decking. There is no documentation on the existing block wall with the coiling door. The architect is requesting additional metal ceiling be removed for better access if needed. Also the electrical contractor shall use the existing recessed troffers for additional access.

PRIOR APPROVALS:

The following materials and/or suppliers, in addition to those specified, have been approved as acceptable for use on the project contingent on compliance with the specifications and performance criteria as specified. All items are subject to the submittal and final approval of shop drawings and product data by the successful contractors and/or suppliers.

1. NA

End of Addendum

**SECTION 00 4100
BID FORM**

THE PROJECT AND THE PARTIES

1.01 TO:

- A. Owner
- B. North Dakota Department of Commerce (Owner)
I-94 Apple Creek West Bound Rest Area
Menoken, North Dakota 58558

1.02 FOR:

- A. Project: ND Department of Commerce Apple Creek Rest Area Renovation
- B. Architect's Project Number: J22401
I-94 Apple Creek West Bound Rest Area
Menoken, North Dakota 58558
- C. Bidder (General, Electrical): _____

1.03 DATE: _____ (BIDDER TO ENTER DATE)

1.04 SUBMITTED BY: (BIDDER TO ENTER NAME AND ADDRESS)

- A. Bidder's Full Name _____
 - 1. Address _____
 - 2. City, State, Zip _____

1.05 OFFER - BASE BID

- A. Having examined the Place of The Work and all matters referred to in the Instructions to Bidders and the Contract Documents prepared by J2 Studio Architecture + Design, PC for the above mentioned project, we, the undersigned, hereby offer to enter into a Contract to perform the Work for the Sum of:
- B. _____ dollars
(\$ _____), in lawful money of the United States of America.
- C. We have included the required security deposit as required by the Instruction to Bidders.
- D. We have included the required performance assurance bonds in the Bid Amount as required by the Instructions to Bidders.
- E. All applicable federal taxes are included and State of North Dakota taxes are included in the Bid Sum.

1.06 ACCEPTANCE

- A. This offer shall be open to acceptance and is irrevocable for (60) sixty days from the bid closing date.
- B. If this bid is accepted by Owner within the time period stated above, we will:
 - 1. Execute the Agreement within seven days of receipt of Notice of Award.
 - 2. Commence work within seven days after written Notice to Proceed of this bid.
- C. If this bid is accepted within the time stated, and we fail to commence the Work or we fail to provide the required Bond(s), the security deposit shall be forfeited as damages to Owner by reason of our failure, limited in amount to the lesser of the face value of the security deposit or the difference between this bid and the bid upon which a Contract is signed.
- D. In the event our bid is not accepted within the time stated above, the required security deposit shall be returned to the undersigned, in accordance with the provisions of the Instructions to Bidders; unless a mutually satisfactory arrangement is made for its retention and validity for an

extended period of time.

1.07 CONTRACT TIME

- A. If this Bid is accepted, we will:
- B. Complete the Work by the _____ day of _____, _____. (Bidder to enter day, month, and year.)

1.08 CHANGES TO THE WORK

- A. When Architect establishes that the method of valuation for Changes in the Work will be net cost plus a percentage fee in accordance with General Conditions, our percentage fee will be:
 - 1. _____ percent overhead and profit on the net cost of our own Work;
 - 2. _____ percent on the cost of work done by any Subcontractor.

1.09 ADDENDA

- A. The following Addenda have been received. The modifications to the Bid Documents noted below have been considered and all costs are included in the Bid Sum.
 - 1. Addendum # _____ Dated _____.
 - 2. Addendum # _____ Dated _____.
 - 3. Addendum # _____ Dated _____.
 - 4. Addendum # _____ Dated _____.
 - 5. Addendum # _____ Dated _____.

1.10 BID FORM SUPPLEMENTS

- A. We agree to submit the following Supplements to Bid Forms within 48 hours after submission of this bid for additional bid information:
 - 1. Document 00 4336-Proposed Subcontractors Form: Include the names of all Subcontractors and the portions of the Work they will perform.
 - 2. Document 00 4373 - Proposed Schedule of Values Form identifies the Bid Price/Sum segmented into portions as requested.

1.11 BID FORM SIGNATURE(S)

- A. The Corporate Seal of
- B. _____
- C. **(Bidder - print the full name of your firm)**
- D. was hereunto affixed in the presence of:
- E. _____
- F. **(Authorized signing officer, Title)**
- G. (Seal)
- H. _____
- I. **(Authorized signing officer, Title)**

1.12 IF THE BID IS A JOINT VENTURE OR PARTNERSHIP, ADD ADDITIONAL FORMS OF EXECUTION FOR EACH MEMBER OF THE JOINT VENTURE IN THE APPROPRIATE FORM OR FORMS AS ABOVE.

END OF SECTION

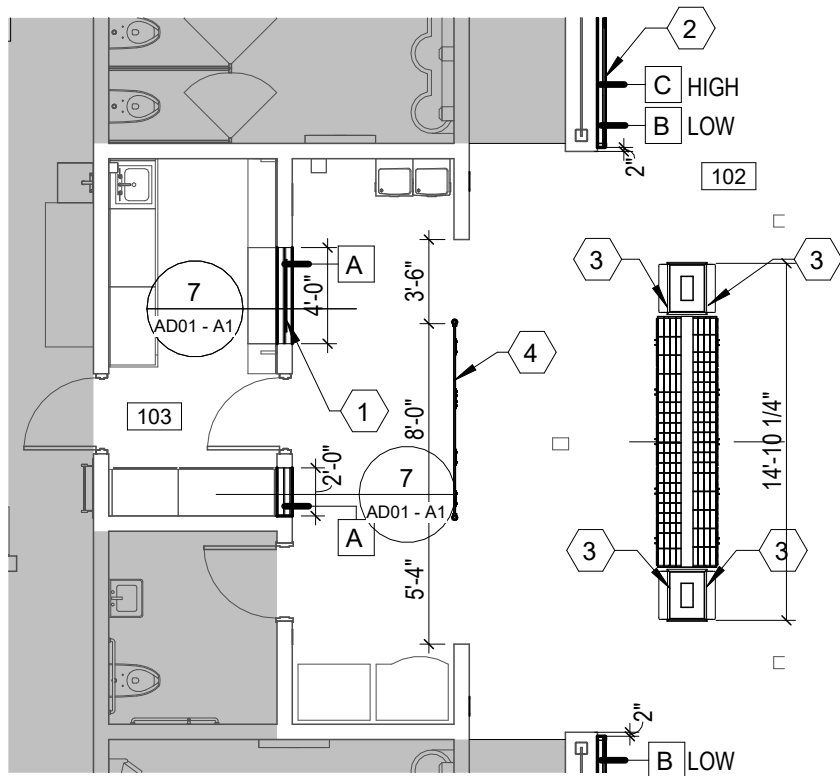

1 Partial Main Floor Renovation Plan
Scale: 1/8" = 1'-0"

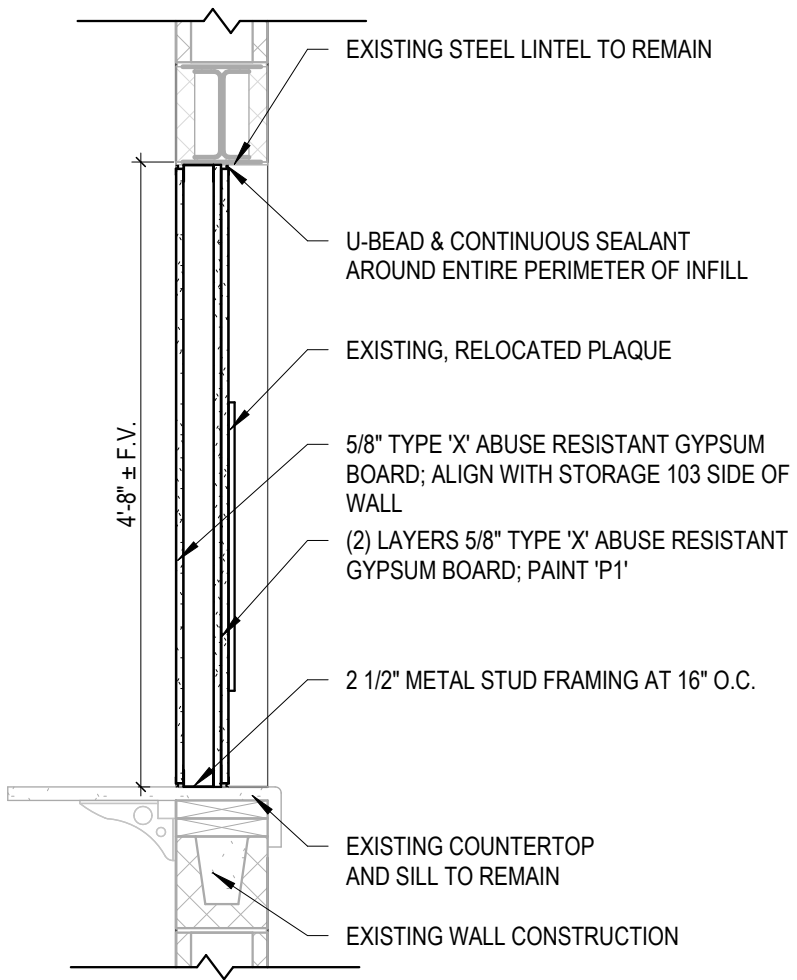

6 Wall Section
Scale: 3/4" = 1'-0"

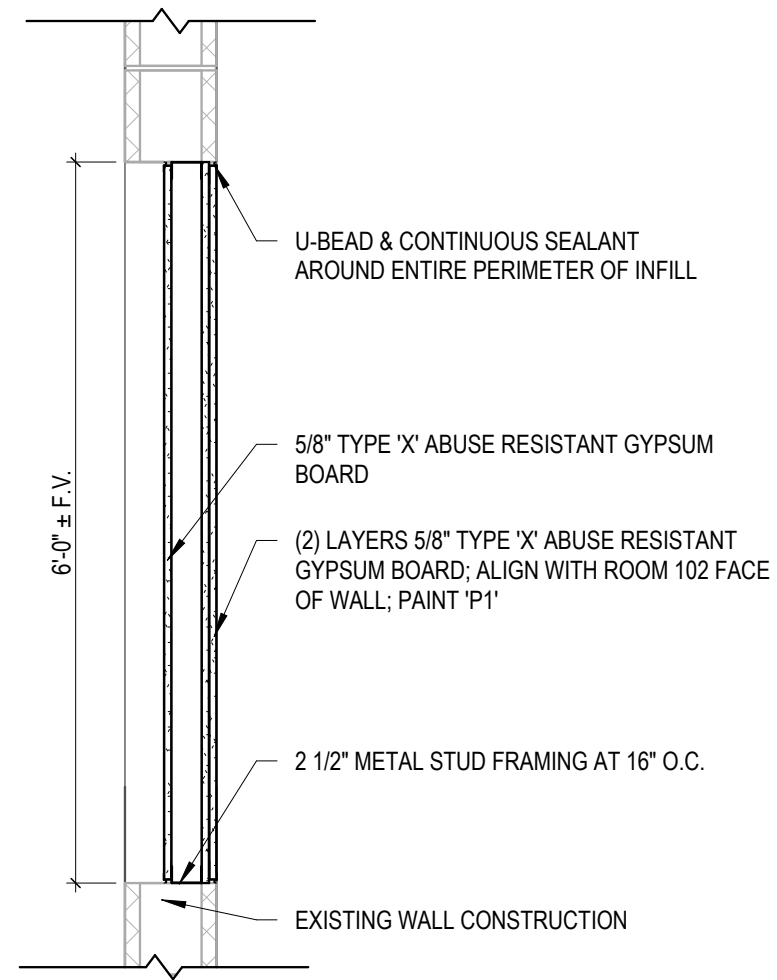

7 Wall Section
Scale: 3/4" = 1'-0"

ND Department of Commerce
Apple Creek Rest Area Renovation
Bismarck, ND



919 South 7th Street, Suite 400
Bismarck, ND 58504
(701) 255-1622

© 2024 All Rights Reserved

December 23, 2024
J2 Project No. J22401

Addendum #
1

A1

Planholders List - J22401

North Dakota Department of Commerce
 Apple Creek Rest Room Renovation
 Bismarck, ND



Set	Planholder	Mailing Address	City	State	Zip	Phone #	Fax #	Contact Name
1	North Dakota Department of Commerce	1600 E. Century Avenue, Suite 6	Bismarck	ND	58503	701-328-5372	-	Heather LeMoine
E	J2 Studio Architecture + Design	919 S. 7th Street, Suite 400	Bismarck	ND	58504	701-255-1622	701-223-8927	James Devine/Carrie Meyer
E	Apex Engineering	600 South Second Street, Suite 145	Bismarck	ND	58504	701-323-3950	-	John Klein
E	Capital City Construction	1501 E Calgary Avenue	Bismarck	ND	58503	701- 255-4002	701- 222-0731	Jayden Haider
E	Dakota West Contracting	P.O. Box 2377	Bismarck	ND	58504	701-255-0004	701-255-7626	Brandon Feser
E	Northwest Contracting	2840 Valley Forge Street	Bismarck	ND	58503	701-255-7727	701-255-2825	Jennifer Krause
E	Paramount Builders	1407 Tacoma Avenue	Bismarck	ND	58504	701-258-0088	-	Jarred Roloff
E	Roers Construction	1260 West Villard	Dickinson	ND	58602	701- 483-1686	-	Matt Thomas/Dave Reis
E	Edling Electric	P.O. Box 1451	Bismarck	ND	58502	701-255-2831	701-255-2835	Jason Rodd
E	Frontier Electric	1333 S. 22nd Street	Bismarck	ND	58504	701-222-8893	701-222-8586	Rich Schwingler
E	Magnum Electric	820 S. 18th Street	Bismarck	ND	58504	701-751-3033	-	Jace Murschel
E	Oztech Electric	1312 Basin Avenue, Suite B	Bismarck	ND	58504	701-390-6886	-	Brian Osmond
E	RK Electric	4100 Centurion Dr.	Bismarck	ND	58504	701-255-1864	-	Randy Koch
E	Skeels Electric Co.	PO Box 5009	Bismarck	ND	58502	701-223-5440	701-255-1797	Thomas Wolf
E	Bismarck-Mandan Builders Exchange	805 Adobe Trail SE	Mandan	ND	58554	701-667-4322	701-667-5217	Julie Monzelowsky
E	Bismarck Builders Exchange	215 Airport Rd	Bismarck	ND	58504	701-258-4215	701-258-1391	Sandy Kerzman
E	Fargo-Moorhead Builders Exchange	1010 Page Dr	Fargo	ND	58103	701-237-6772	701-232-1653	Calisa Nickelson
E	Minnesota Builders Exchange	1123 Glenwood Avenue	Minneapolis	MN	58405	612-381-2620	701- 381-2621	Jeff Boelter
E	Builders Exchange of Billings	2050 Broadwater Ave, Suite A	Billings	MT	59102	406-652-1311	406-652-1391	Luke Hudson
E	Bozeman Planroom	1105 Reeves Rd W, Suite 800	Bozeman	MT	59718	406-586-7653	406-586-4062	Stan Wagner
E	Missoula Builders Exchange	201 N Russell St	Missoula	MT	59801	406-549-5502	406-721-2941	Twyla Brooks
E	Construction Industry Center	2771 Plant St	Rapid City	SD	57702	605-343-5252	605-343-4591	Kasi Kuiper
E	Dodge Construction Network	2860 S. State Highway 161, Suite 160 #151	Grand Prairie	TX	75052	844-326-3826 ext. 2943	-	Brandi Flanagan
E	Construct Connect							Lore Siga

Printed Copies = \$2.10/sheet for drawings and \$.12/page for specifications

